

THERMACUT[®]

EX-TRAFIRE[®]

40SD

PLASMA ARC CUTTING SYSTEM

Service information and spare parts list

Revision: R-1
English
2024



SERVICE INFORMATION

Based on the Commission Regulation (EU) 2019/1784 of October 1, 2019, which establishes the requirements for the eco-design of welding equipment according to the directive of the European Parliament and the Council 2009/125/EC, we provide subsequent service support for electrical equipment - plasma cutting of the energy supply in the following ways:

The plasma power supply spare parts list you can find in this document including exploded view. Free access to this document: www.thermacut.cz, www.ex-trafire.com, see the section SERVICE INFORMATION and open or download this document.

Authorised representatives or importers of plasma cutting equipment shall make available to professional repairers at least the spare parts for a minimum period of 10 years after the production of the last unit of a plasma cutting system.

Service may only be provided by authorized personnel who have access to service and repair information. In case of service request please contact your authorised representatives or importers who will provide or organize professional repair minimally during warranty period.

The warranty period is:

- Three (3) years for EX-TRAFIRE® brand power supplies
- One (1) year for torches and lead sets

The Warranty does not cover reasonable wear and tear of the Goods or associated parts, which include consumables such as: Electrodes, Nozzles, Swirl Rings, Retaining Caps, Shields, and O-rings.

Warranty terms and conditions vary to suit diverse markets and country directives.

Maximum delivery time for spare parts:

The manufacturer, importer or authorised representative shall ensure the delivery to professional repairers of spare parts for plasma cutting equipment within 15 working days after having received the order.

The manufacturer, importer, authorised representative or professional repairers will find spare parts ordering information in the eCatalog (through authorized access to this application) based on the power supply serial number.

SPARE PARTS LIST

Exploded view drawing

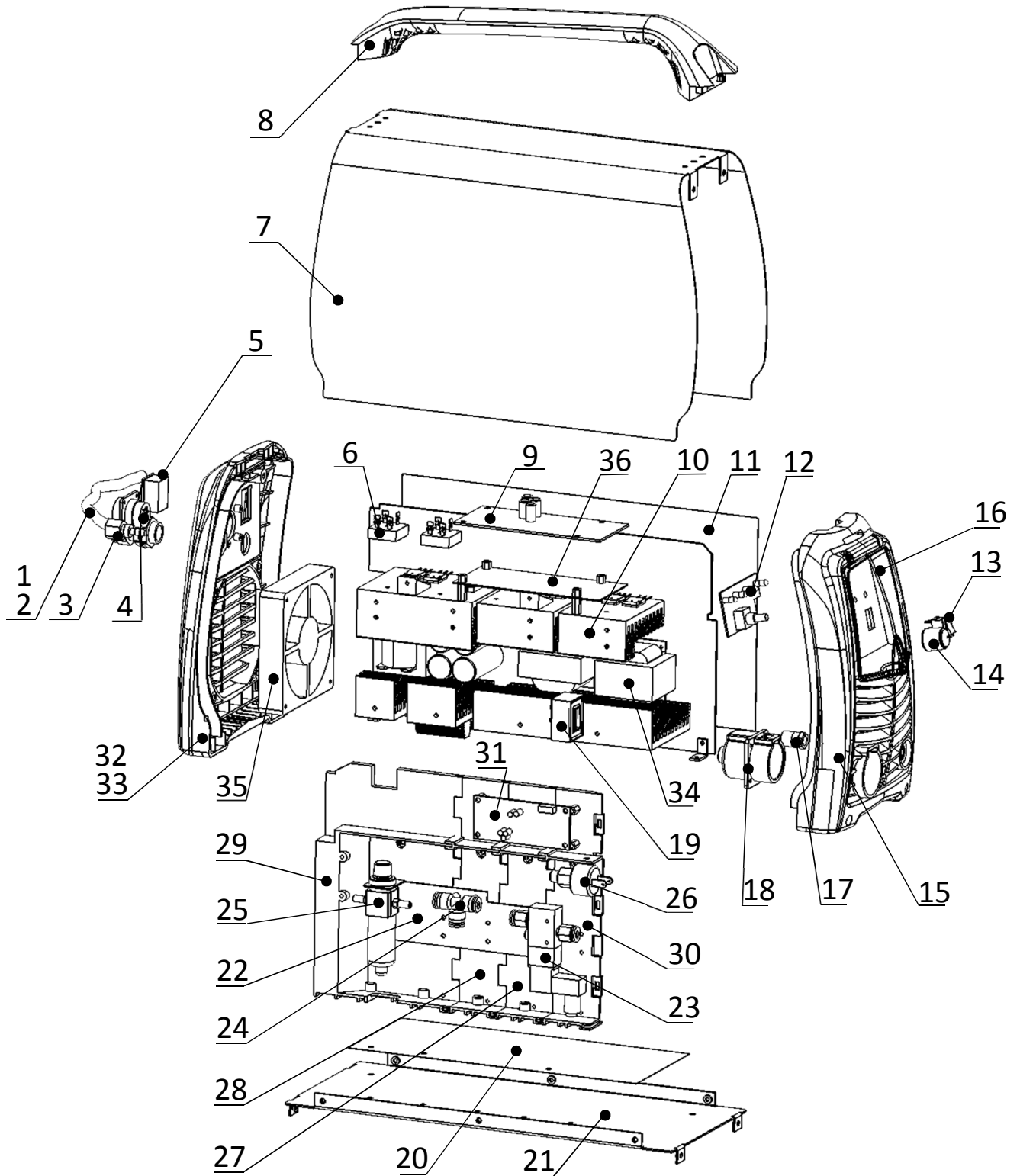

Parts description

Item	DESCRIPTION
1	Input cable (EU standard)
2	Cable clamp
3	Gas inlet connector
N/S	Gas inlet connector (DN7.2ES)
N/S	Gas inlet nut
4	CNC Interface 14-pin socket
5	Power switch
6	Input rectifier
7	Cover
8	Handle
9	Control PCB 40SD
10	Power block (Power block PCB assembly)
11	Isolation plastic sheet
12	Front PCB
13	Rocker (Mode) switch
14	Knob
15	Front panel
16	Front panel protective cover
N/S	Front label
17	10-25SQ-IF Connector
18	TCS socket body TCS13
N/S	Female Crimp Pin for TCS Socket
N/S	Conduit-Brass insert
N/S	Nut M8
19	Hall sensor
20	Plastic sheet (bottom of PS)
21	Base panel
22	Installation panel of Solenoid Valve
23	Gas solenoid (2 way)
24	3-way (T type) gas connector
25	Gas regulator
N/S	Gas regulator connector
N/S	Seal ring
26	Pressure switch
27	Middle plastic panel
28	Middle plastic panel
29	Middle plastic panel
30	Middle plastic panel
31	CNC PCB
32	Rear panel
33	Rear label
34	Output coil
35	Fan
36	Plastic sheet

Item	DESCRIPTION
N/S	Pilot IGBT
N/S	Power IGBT
N/S	Ring Terminal M8/10mm ²
N/S	Work lead with clamp /4m/10
N/S	Work lead with clamp /8m/10
N/S	Work lead with clamp /15m/10
N/S	Work lead with clamp /23m/10
N/S	EU-plug IM 10-25mm ²
N/S	Fast recovery diode (FRD)
N/S	Fast recovery diode (FRD)
N/S	Work clamp M8/300A
N/S	Work C-clamp M8/300A
N/S	Belt

Note: N/S - Not shown items

ADDRESSES AND CONTACTS:

THERMACUT, K.S.

HEADQUARTERS AND PRODUCTION:

THERMACUT, k.s.

Sokolovská 574, Mařatice

686 01 Uherské Hradiště

CZECH REPUBLIC

Tel.: +420 572 420 411

Fax: +420 572 420 420

E-mail: info@thermacut.cz

reditelstvi@thermacut.cz

www.thermacut.cz

SALES DEPARTMENT:

Dukelská 76a,

742 42 Šenov u Nového Jičína

CZECH REPUBLIC

Tel.: +420 556 423 418, 440

Fax: +420 556 423 443, 444

E-mail: sales@thermacut.cz

obchod@thermacut.cz

www.thermacut.cz

THERMACUT GMBH

Am Rübgarten 2

57299 Burbach

GERMANY

Tel.: +49 (0)2736 29 49 11 - 0

Fax: +49 (0)2736 29 49 11 - 77

E-mail: info@thermacut.de

www.thermacut.de

SUBSIDIARIES:

THERMACUT CROATIA D.O.O.

Daničićeva 12

532 70 Senj

CROATIA

Tel.: +385 53 882 599

Fax: +385 53 882 622

E-mail: thermacut@gs.t-com.hr

THERMACUT HUNGÁRIA KFT.

Petőfi Sándor utca 37 atd.

2500 Esztergom

HUNGARY

Tel.: +36 33 502 090,1

Fax: +36 33 400 004

E-mail: info@thermacut.hu

www.thermacut.hu

THERMACUT SLOVAKIA, S.R.O.

Priemyselná ulica 1239

93101 Šamorín

SLOVAKIA

Tel.: +421 31 591 0121

Fax: +421 903 644 954

E-mail: obchod@thermacut.sk

www.thermacut.sk

THERMACUT FRANCE

6 Rue des Frères Lumiere

67201 Eckbolsheim

FRANCE

E-mail: thermacut@thermacut.fr

Tel.: +33 3 88 76 25 78

www.thermacut.fr

THERMACUT-POLAND SP. Z O.O.

ul. Stawowa 20

43-400 Cieszyn

POLAND

Tel: +48 33 852 13 34

E-mail: thermacut@thermacut.pl

www.thermacut.pl

THERMACUT ROMANIA SRL

B-dul 1 Decembrie 1918 nr. 127A

540445 Tg. Mures, Jud. Mures

ROMANIA

Tel.: +40 265 269 520, 263 205

Fax: +40 265 250 317

E-mail: office@thermacut.ro

www.thermacut.ro

ALEXANDER BINZEL (UK) LTD./

THERMACUT UK

Mill Lane, Winwick Quay

Warrington, Cheshire, WA2 8UA

Tel: +44(0) 1925 653944

Fax: +44(0) 1925 654861

Email: info@abimail.co.uk

www.binzel-abicor.co.uk

Distributor details:

THERMACUT®
THE CUTTING COMPANY®

THERMACUT, k. s.
Sokolovská 574, Mařatice
686 01, Uherské Hradiště
Czech Republic
www.thermacut.cz
sales@thermacut.cz

THERMACUT®, FHT-EX® and EX-TRAFIRE® are registered trademarks of THERMACUT, k.s.
and may be registered in Czech Republic and/or other countries.
All other trademarks are properties of their respective owners.